

Bayonet-Ultra Recuperator Worksheet

Worksheet 318
1/15/2010

Customer P.O. _____ Eclipse S.O. _____
 Customer _____ Eclipse Rep _____
 Customer Signature _____ Eclipse Rep Signature _____
 Date _____ Date _____

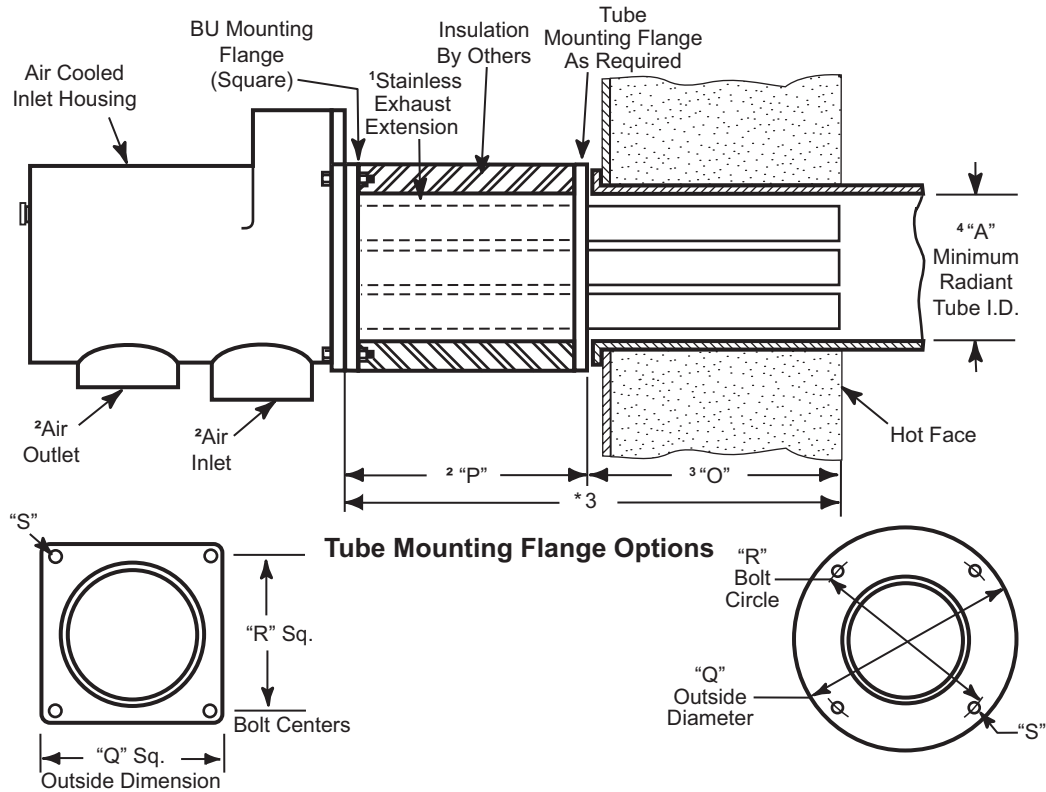

- ¹ Included with recuperator, non-standard flanges have extended lead times.
- ² Do not reverse inlet and outlet connections or the recuperator may overheat.
- ³ Tube ends must not extend past the inner face of the furnace wall more than 50 mm.
- ⁴ Dimension A is the minimum tube ID required.
- * Dimensions must be supplied by the customer.

Actual Exhaust Leg*

A. Tube ID _____ mm
O. Insolation Thk. _____ mm
P. Exhaust Ext. Lg. _____ mm
 (75 - 350mm in 25mm increments)
 For "Q" and "R" below, specify:
 Square or Round
Q. Mounting Flg. _____ mm
R. Bolt Circle _____ mm
S. Bolt Hold Dia. _____ mm

Flange	Dimensions in mm			
	A	Q	R	S
3 BU Square	73.0	133.4	107.9	14.3
4 BU Square	95.3	158.8	133.4	14.3
4 BU Round	95.3	200.0	152.0	14.3
5 BU Square	123.8	184.2	158.8	14.3
6 BU Square	139.7	209.6	184.2	14.3

Approval

Engineer _____ Date _____
 Approved
 Changes Required _____

